

- AHLMANN
- AMMANN
- ATLAS
- BENFORD
- BOBCAT
- CAT MINING
- CATERPILLAR
- CNH
- DOOSAN
- FERMEC
- FUCHS
- FURUKAWA
- HITACHI
- JCB
- KOBELCO
- KOMATSU
- KRAMER
- KUBOTA
- LIEBHERR
- O&K
- SENNEBOGEN
- TAKEUCHI
- TEREX
- VOLVO
- WACKER
NEUSON
- WEIDEMANN
- WEYCOR
- WIRTGEN
- YANMAR

SPARE PARTS

FOR CONSTRUCTION MACHINERY



WE **LOVE** CONSTRUCTION MACHINERY

KRAEMER
BAUMASCHINEN

And have done so for over 50 years. As a second-generation family-owned company, we are a competent partner of the building sector and industry in North-Rhine Westphalia. **Kraemer BAUMASCHINEN** is an authorised dealer and distributor of the Doosan and Weycor brands.

KRAEMER
ERSATZTEILE

Kraemer ERSATZTEILE offers solutions and parts for fair-value repairs of a large variety of construction machinery over their entire service life.

KRAEMER
MINING

Kraemer MINING responds to the special demands and requirements within the mining industry, ensuring the rapid, reliable and cost-saving supply of spare and wear parts.





**WE TRADE
WORLDWIDE**

IN PROCUREMENT AS WELL AS DISPATCH,
WHEREVER YOU ARE AND WHEREVER YOUR
MACHINERY IS LOCATED - OUR PARTS ARRIVE.

HOW DOES THE KRAEMER SPARE PARTS SERVICE WORK?

Kraemer ERSATZTEILE offers solutions and parts to meet your requirements. Practically oriented to ensure fair-value repairs of your construction machinery!

Our product range includes spare, wear and maintenance parts for a large range of manufacturers and types. A reliable supplier network with strong partners constitutes the basis for a rapid supply of parts. In addition to original parts, we offer alternatives, mostly of original equipment manufacturer quality, with an excellent price/performance ratio. This allows us to accompany your machinery throughout their service life.

Our employees have added to their technical knowledge over decades and we like to pass this on to our customers. We are your personal and reliable partner for your complete machinery fleet. Competent, solution-oriented and reliable.

MILESTONES IN OUR HISTORY

Gradually growing, we have managed to establish a reliable supplier network over a period of decades. In order to be ready for the future, we enter into additional strategic partnerships. Most recently, FMC, HELLA Mining and Kubota have joined us as major partners.

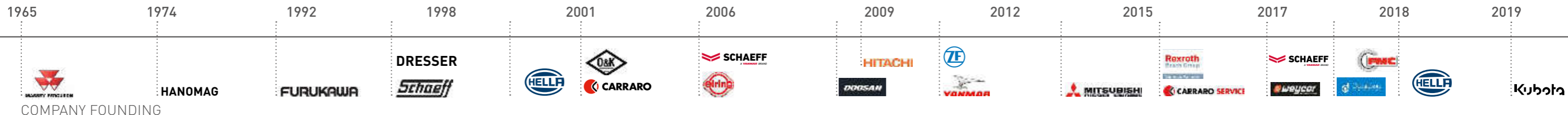

FAIR-VALUE REPAIRS

WE CAN OFFER YOU SPARE PARTS IN THREE DIFFERENT QUALITY LEVELS, SUITABLE FOR THE ENTIRE SERVICE LIFE OF YOUR MACHINERY.

YOUR BENEFITS

- ✓ Competence acquired through over 50 years of experience
- ✓ More than 5,000 customers worldwide trust us
- ✓ Solutions for fair-value repairs of machinery from various manufacturers
- ✓ International supplier network with strong partners
- ✓ The latest warehouse technology, with daily express delivery
- ✓ Over 9 million items can be identified and ordered via the Kraemer system
- ✓ Over 22,000 spare parts always in stock
- ✓ Original parts or original equipment manufacturer quality
- ✓ Languages: DE, EN, RU and others
- ✓ Competent, solution-oriented and reliable

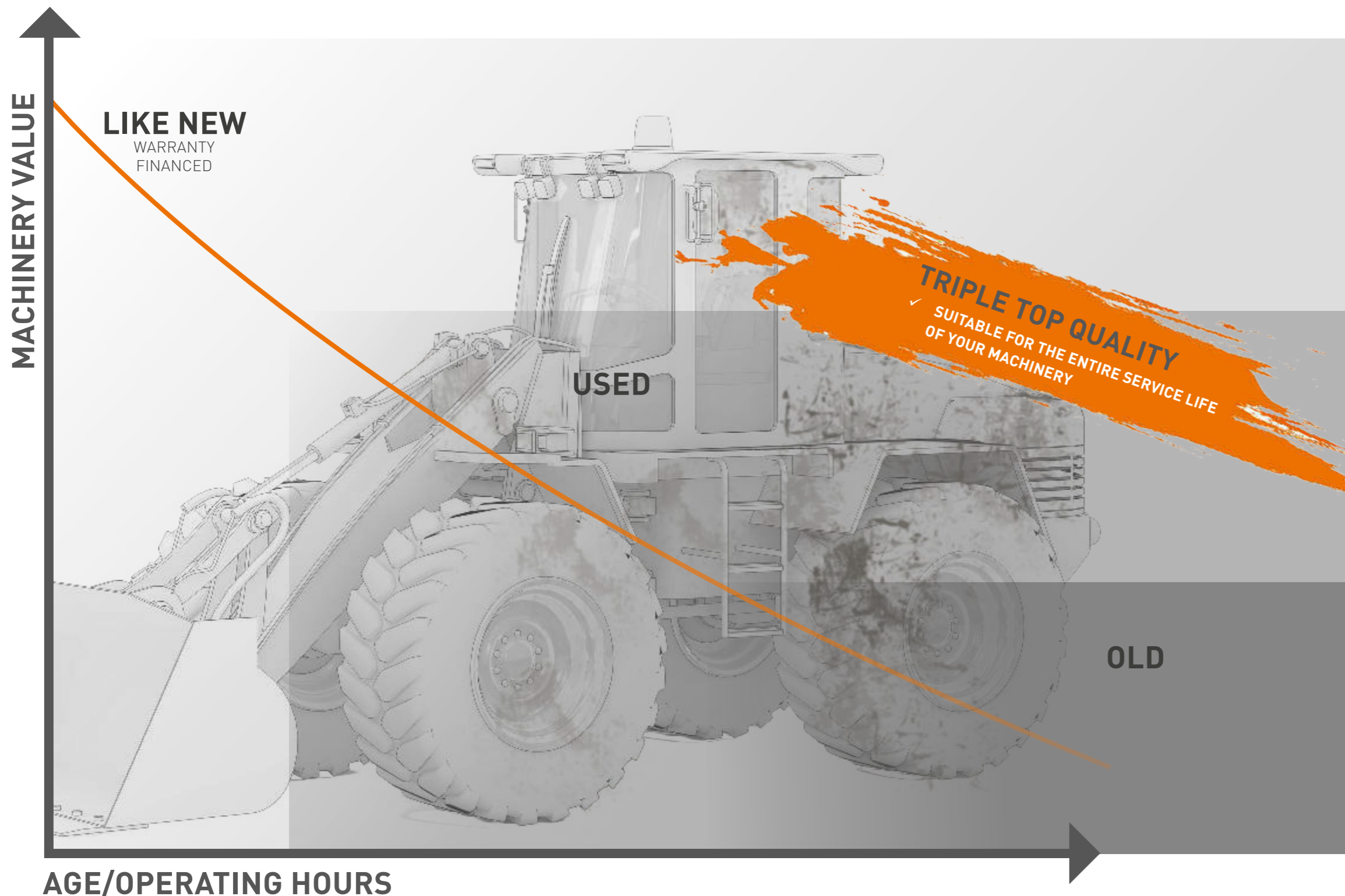

Kraemer ORIGINAL Parts

Original from the machinery manufacturer. For efficient construction machinery maintenance or repairs. To back up the warranty. Our large range meets your requirements for your new construction machinery.

Kraemer PREMIUM Parts

Original equipment manufacturer quality, for high-quality construction machinery maintenance or repairs. Guaranteed original equipment manufacturer quality for spare parts for excavators, earthmovers, mobile excavators and mini-excavators.

Kraemer-SMART-Parts

Selected products with an excellent price/performance ratio. This well-priced range allows us to meet your demand for products at attractive prices. Replica, replacement and used parts.

FILTER AND MAINTENANCE KITS

- ✓ Oil, air and fuel filters
- ✓ Seals and sealing kits
- ✓ Belts



MOTOR PARTS

- ✓ Starters and generators
- ✓ Turbochargers
- ✓ Seals and sealing kits
- ✓ Cylinders, pistons, bushes
- ✓ Fans and radiators
- ✓ Injection, water and fuel pumps



MISCELLANEOUS

- ✓ Illumination
- ✓ Central lubricating systems
- ✓ Pedals and Bowden cables
- ✓ Keys, locks and handles
- ✓ Ring gears
- ✓ Glass panes



WEAR PARTS

- ✓ Teeth/blades
- ✓ Steel/rubber chains
- ✓ Bushings and bolts
- ✓ Idler and sprocket
- ✓ Top and bottom rollers

HYDRAULIC PARTS

- ✓ Hydraulic motors and pumps
- ✓ Hoses and screw connections
- ✓ Seals and sealing kits
- ✓ Valves
- ✓ Rotary transmissions

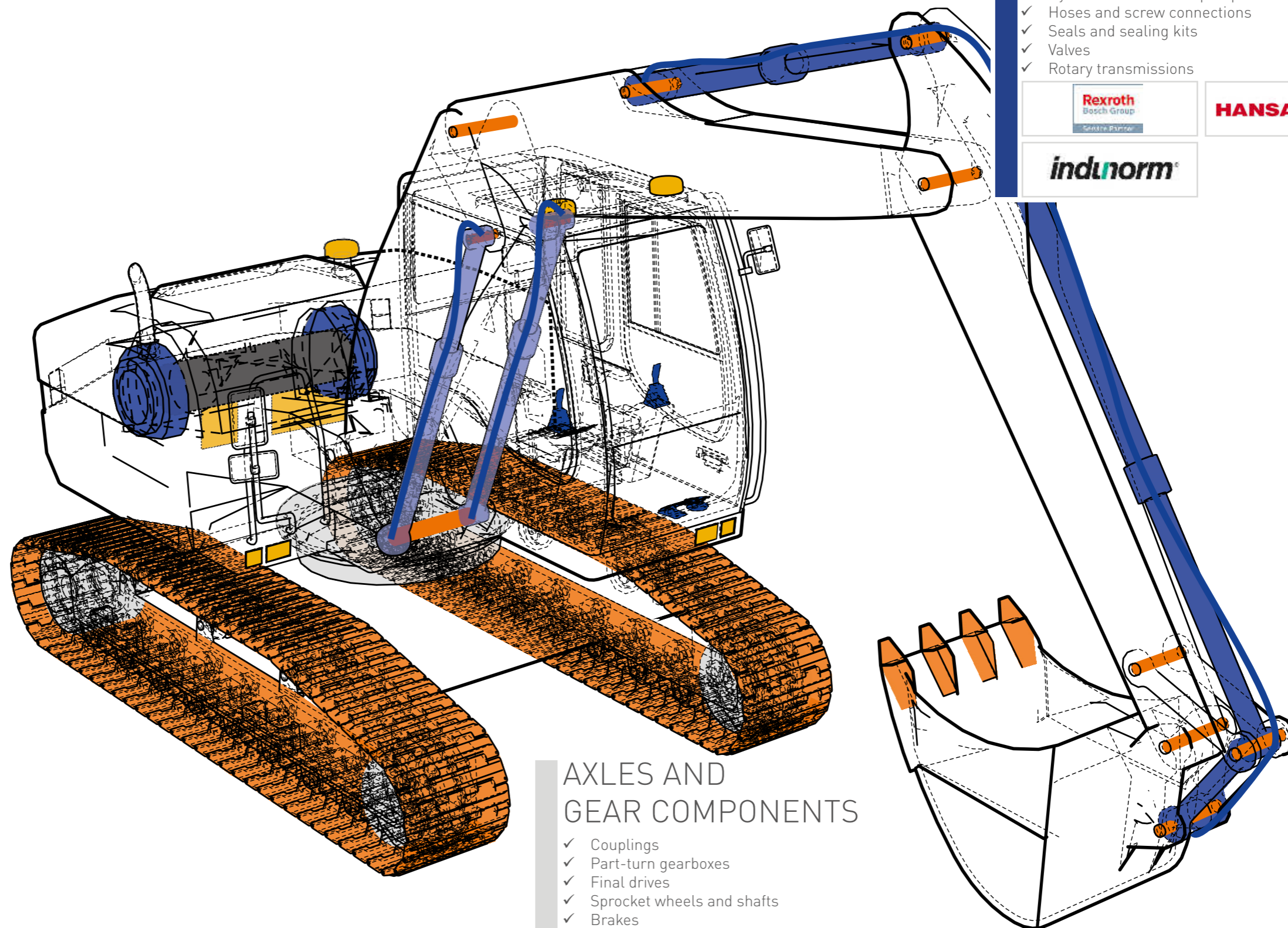

AXLES AND GEAR COMPONENTS

- ✓ Couplings
- ✓ Part-turn gearboxes
- ✓ Final drives
- ✓ Sprocket wheels and shafts
- ✓ Brakes
- ✓ Friction discs





OVER 2,500 COMPONENTS ALWAYS IN STOCK

HOSES AND SCREW CONNECTIONS

Hydraulic hoses are constantly under high pressure and also need to withstand extreme external influences. This means that the highest quality is required to ensure smooth functioning of the machinery. Our range includes pressure and suction hoses in original equipment manufacturer quality for a variety of applications. We are also able to manufacture high-quality 1- to 8-layer hoses in-house.

HANSA/FLEX

indunorm

PRODUCTION
OF 1- TO 8-LAYER HOSES
ACCORDING TO

- ✓ SAMPLES
- ✓ DRAWINGS
- ✓ MANUFACTURER INSTRUCTIONS



Rexroth
Bosch Group

Service Partner
Service Point

SEALS AND SEALING KITS

We are able to offer you a **large range of SEALS** for your machinery fleet. This comprises: **piston and piston rod seals, scrapers, O-rings and support rings**.

In addition, we can supply you with **selected SEALING KITS** for numerous construction machinery, from mini-excavators and chain excavators to wheel loaders, telescopic loaders and mining excavators.



ADDITIONAL SERVICES:
✓ INDIVIDUAL SEALING KITS ON REQUEST

BOSCH REXROTH SERVICE POINT

As a Bosch Rexroth Service Point, we guarantee you the following:

- ✓ **A supply of Bosch Rexroth original spare parts**
- ✓ Field service with on-site fault diagnosis
- ✓ Removal and collection service for faulty hydraulic products
- ✓ Delivery, installation and recommissioning
- ✓ Preventative repairs with parts supply
- ✓ Availability of original spare parts

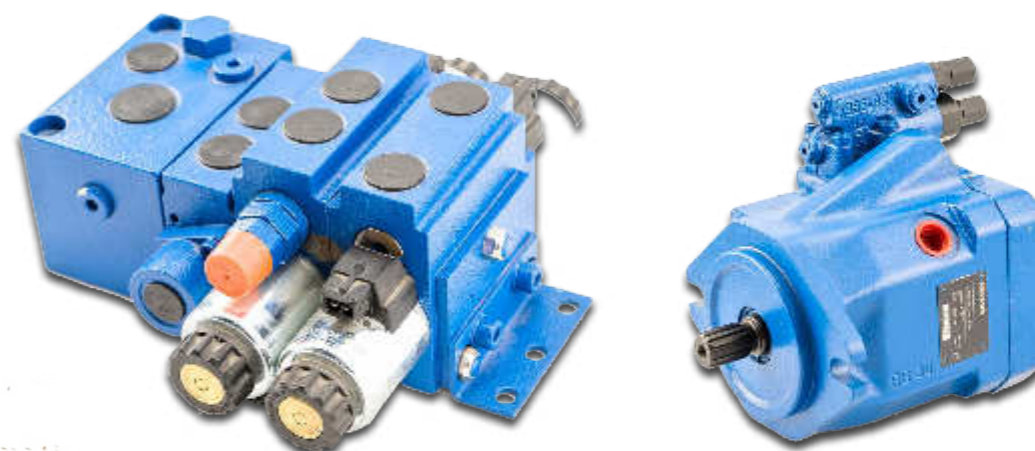

- AHLMANN
- AMMANN
- ATLAS
- BENFORD
- BOBCAT
- CAT MINING
- CATERPILLAR
- CNH
- DOOSAN
- FERMEC
- FUCHS
- FURUKAWA
- HITACHI
- JCB
- KOBELCO
- KOMATSU
- KRAMER
- KUBOTA
- LIEBHERR
- O&K
- SENNEBOGEN
- TAKEUCHI
- TEREX
- VOLVO
- WACKER NEUSON
- WEIDEMANN
- WEYCOR
- WIRTGEN
- YANMAR



OFFICIAL CARRARO SERVICE CENTRE

Carraro Drive Tech is a worldwide market leader in the development, production and marketing of axles, drives and gearboxes.

As a Carraro Service Centre, we offer you:

SUPPLY OF SPARE PARTS

MAINTENANCE OF AXLES, GEARBOXES OR TECHNICAL ASSEMBLIES

- ✓ Qualified staff who regularly participate in Carraro training courses
- ✓ Use of Carraro special tools
- ✓ Use of original spare parts for high-quality repairs
- ✓ Adherence to Carraro specifications



TECHNICAL SUPPORT

- ✓ Torques, settings
- ✓ Assembly instructions
- ✓ Recommendations which other components should be replaced
- ✓ Failure troubleshooting
- ✓ Individual technical advice



IF IT DRIVES, IT DRIVES WITH FMC

FMC products are found in almost all vehicle types: from the building and mining industry to agricultural equipment, utility and special vehicles and even in motor sport. This premium manufacturer provides a large range of friction discs for numerous applications: brakes, differential gearboxes, power shift transmissions, winch systems, torque limiters, swing and operating brakes, steering clutches, PTO transmissions, steel mating plates - any type of friction discs is possible! These can be provided in a variety of materials, such as bronze, carbon, molybdenum, graphite, ceramics, etc.

The result of this extremely wide product range is a spare parts catalogue with almost **5,000** references to many manufacturers.

OUR FEATURES - YOUR ADVANTAGES

- ✓ Short-term availability of > 90% of products
- ✓ Certified references to many manufacturers of doubtlessly suitable products
- ✓ Large range of materials for every application
- ✓ Technical knowledge due to in-house research and development
- ✓ Quick and accurate product development and continuous improvement
- ✓ ISO 9001-certified by TÜV Nord

HIGHEST RELIABILITY AT ZF



When it comes to the products of our premium partner, ZF, we are able to supply you with original spare parts and complete assemblies quickly and reliably. ZF AG, with its registered office in Friedrichshafen on Lake Constance, acts as an original equipment manufacturer of axles and gearboxes for all leading machinery manufacturers. By purchasing original equipment manufacturer quality, you can acquire a part that is technically identical to that used by the machinery manufacturer at an attractive price.



- AHLMANN
- AMMANN
- ATLAS
- BENFORD
- BOBCAT
- CAT MINING
- CATERPILLAR
- CNH
- DOOSAN
- FERMEC
- FUCHS
- FURUKAWA
- HITACHI
- JCB
- KOBELCO
- KOMATSU
- KRAMER
- KUBOTA
- LIEBHERR
- O&K
- SENNEBOGEN
- TAKEUCHI
- TEREX
- VOLVO
- WACKER NEUSON
- WEIDEMANN
- WEYCOR
- WIRTGEN
- YANMAR

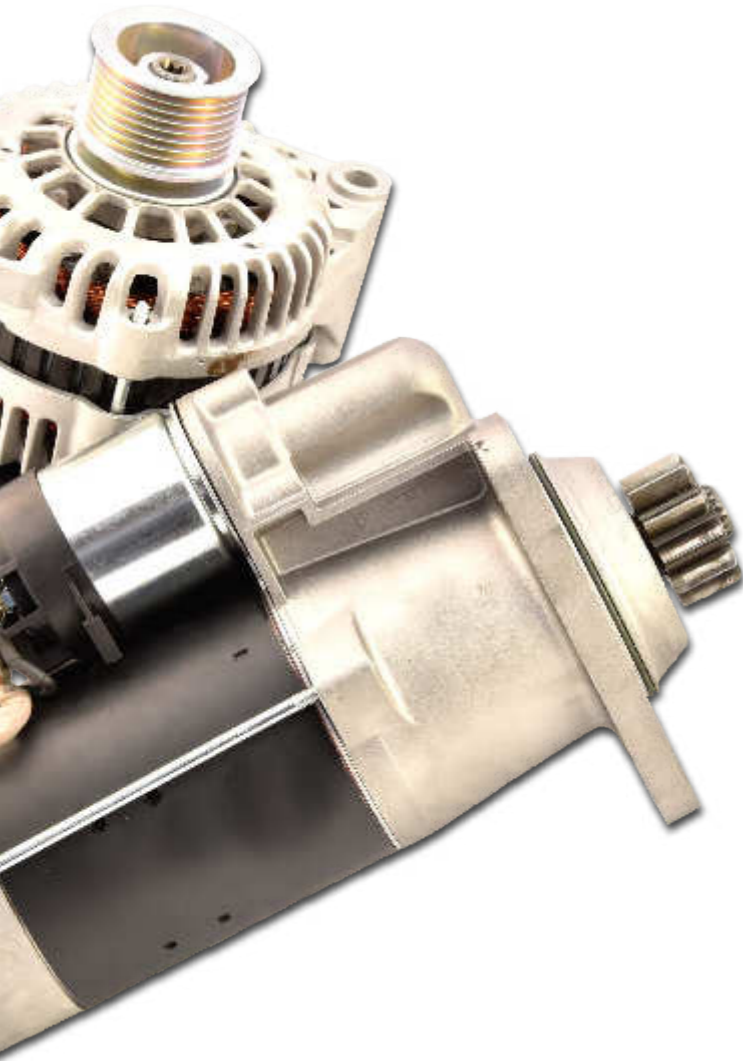

mitsubishi MOTOR SPARE PARTS

When it comes to motor parts, we work together with leading motor manufacturers in order to provide you with a reliable supply and large range of motor spare parts.

Based on our many years of cooperation, among others with our distribution partner Mitsubishi Heavy Industries, we have access to a large range of motor spare parts for all common assemblies and can provide you with these within a short time when required.

We also offer replacement motors, either new or reconditioned. In the event of a replacement, a repaired base engine is usually delivered to you; any add-on parts required by you can then be taken from your motor, so that your old base motor can be returned to our supplier for repair and to replace the one delivered to you. If you wish to enquire about a spare part, please provide your machinery type and serial number, as well as the motor type and motor number, as motors may have different versions, depending on the purpose for which they are used.



Mitsubishi Heavy Industries is a major company established on 7 July 1884, with approximately 400 sites worldwide.

According to the motto, "Move the world forward", modern drive solutions for industry, aviation, shipping and the automotive sector are developed and produced here. In the construction machinery industry, Mitsubishi specialises in motors, producing everything from connecting rod bearing shells to motor sealing kits, pistons, bushes and turbochargers, as well as complete motors, thus providing all the spare parts you need to maintain your machinery!

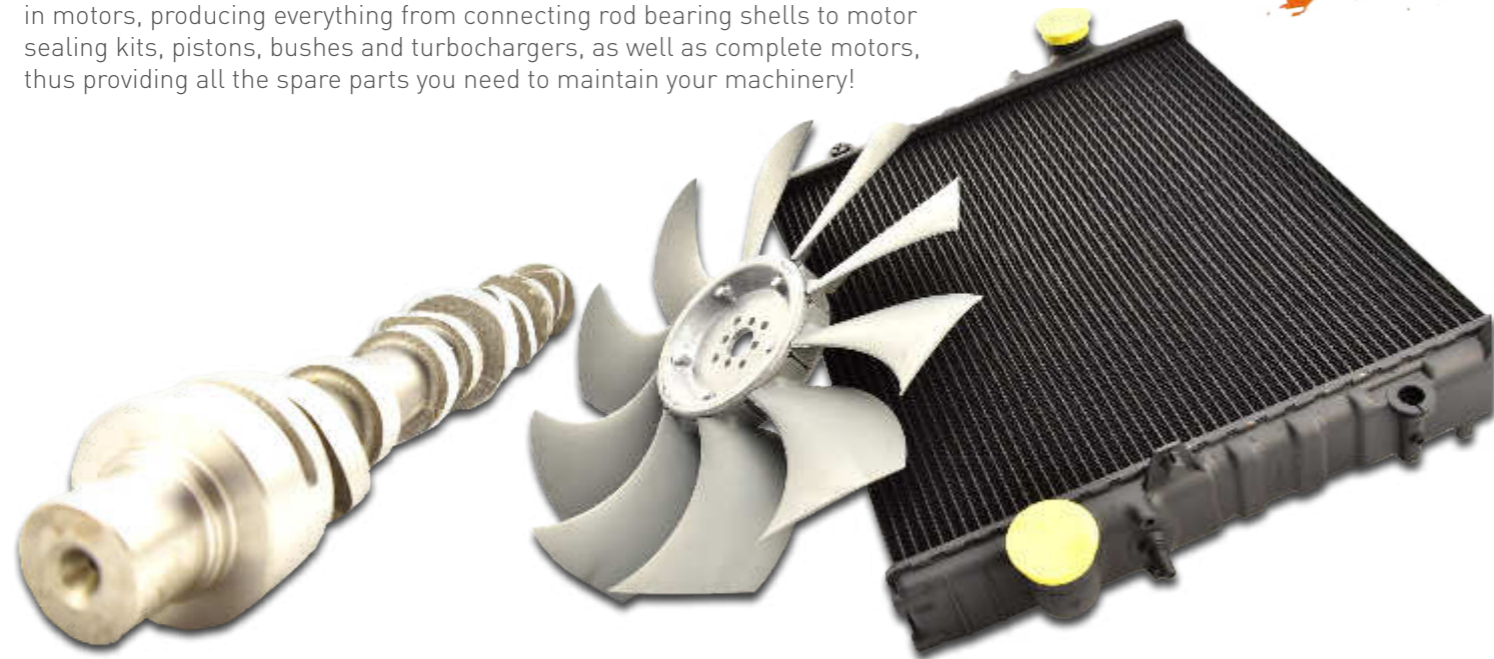

IMMEDIATELY AVAILABLE
✓ LARGE STOCK ON HAND

- ✓ Starters and generators
- ✓ Turbochargers
- ✓ Seals and sealing kits
- ✓ Fans and radiators
- ✓ Cylinders, pistons, bushes
- ✓ Injection, water and fuel pumps

Our product range also comprises premium spare parts for:

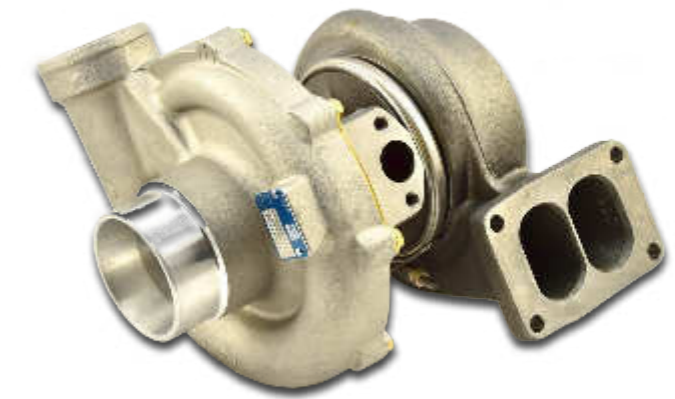

- AHLMANN
- AMMANN
- ATLAS
- BENFORD
- BOBCAT
- CAT MINING
- CATERPILLAR
- CNH
- DOOSAN
- FERMEC
- FUCHS
- FURUKAWA
- HITACHI
- JCB
- KOBELCO
- KOMATSU
- KRAMER
- KUBOTA
- LIEBHERR
- O&K
- SENNEBOGEN
- TAKEUCHI
- TEREX
- VOLVO
- WACKER NEUSON
- WEIDEMANN
- WEYCOR
- WIRTGEN
- YANMAR

DISTRIBUTORS OF DONALDSON FILTRATION SOLUTIONS



Since 01/08/2017, we have been the official distributors for Donaldson Filtration Solutions!

Donaldson is a worldwide leader in filtration systems. Since 1915, Donaldson has been catering for customers in the market for industrial motors and diesel motors, including air purification systems, compressed air and gas cleaning equipment, smoke and dust removal, energy supply, data medium filtration, off-road equipment and lorries.

Since 2017 we have been distributing the products of this leading manufacturer and would be pleased to provide you with suitable filters for your machinery!



MANY FILTER SOLUTIONS FOR OTHER WELL-KNOWN MANUFACTURERS

TELL US YOUR:

- ✓ MACHINERY TYPE
- ✓ SERIAL NUMBER
- ✓ MAINTENANCE INTERVAL (500-2,000 H)

We offer you individually compiled and pre-packaged maintenance kits for your construction machinery. In addition to all filters, our kits also include fan belts and seals.



SPARE PARTS FOR YOUR UNDERCARRIAGE

From mini-excavators to mining equipment, we can provide you with all spare parts for your undercarriage. Irrespective of whether you require components or complete undercarriage, our decades of experience always enable us to provide you with the appropriate products.

We work together with almost all original equipment manufacturers, in order to be able to provide you with the best quality for your undercarriage components.

By offering several quality and price levels, we are always able to provide you with fair-value spare parts for your machinery.

- ✓ Steel/rubber chains
- ✓ Idler and sprocket
- ✓ Support and track rollers



IMMEDIATELY AVAILABLE

- ✓ LARGE STOCK ON HAND
- ✓ DAILY DELIVERY

ASSISTANCE WITH WEAR PARTS

In addition to undercarriage components, we also offer a large range of teeth, blades, bushings and bolts.



- AHLMANN
- AMMANN
- ATLAS
- BENFORD
- BOBCAT
- CAT MINING
- CATERPILLAR
- CNH
- DOOSAN
- FERMEC
- FUCHS
- FURUKAWA
- HITACHI
- JCB
- KOBELCO
- KOMATSU
- KRAMER
- KUBOTA
- LIEBHERR
- O&K
- SENNEBOGEN
- TAKEUCHI
- TEREX
- VOLVO
- WACKER NEUSON
- WEIDEMANN
- WEYCOR
- WIRTGEN
- YANMAR



HELLA LIGHTING

We can offer you a customised lighting concept, specifically tailored to each of your machinery, their applications and the environment.

As the exclusive partner of Hella Mining in the Germany, Austria and Switzerland region, we can ensure a better view, visibility, productivity and risk minimisation. To this can be added the cost savings effected by shorter down-times and maintenance costs, as well as a five-year warranty for LED products, ensuring that no further investment is required on your part. In addition to mining products we do, also stock other Hella products.

BETTER LIGHT USING BETTER TECHNOLOGY

- ✓ HELLA MINING: DACH - ONLY FROM KRAEMER



LIGHTING, AS HARD AS THE JOB ITSELF

- ✓ Detailed calculations and advice on optimal illumination
- ✓ Glare reduction by **ZEROGlare** technology
- ✓ Less driver fatigue due to 5,000 K light temperature
- ✓ No radio signal interference
- ✓ Corrosion resistance due to NanoSafe coating
- ✓ High resistance: resistant to temperature, impact, vibration, dust and water penetration (including high-pressure cleaning equipment)
- ✓ 5-year warranty for LED products
- ✓ A wide range of tried and trusted Hella quality products



* 5-year warranty for all LED products from the manufacturing date

CENTRAL LUBRICATION SYSTEMS

If you want to reduce the maintenance effort and wear and tear of your machinery, we can offer you complete solutions for reliable lubrication with the aid of our premium partners SKF and BEKA MAX.

Centralised lubrication systems fully automatically lubricate your machinery at predefined intervals. Retrofitting a centralised lubrication system is not only useful for new machinery; it can be an equally useful solution for your older machinery.

We will gladly compile an individual quotation for you and will also ensure a supply of spare parts at all times.



EXTENDED RANGE

In addition to the products listed above, you can also obtain the following items at competitive prices from us:

- ✓ Pedals and Bowden cables
- ✓ Keys, locks and handles
- ✓ Ring gears
- ✓ Glass panes

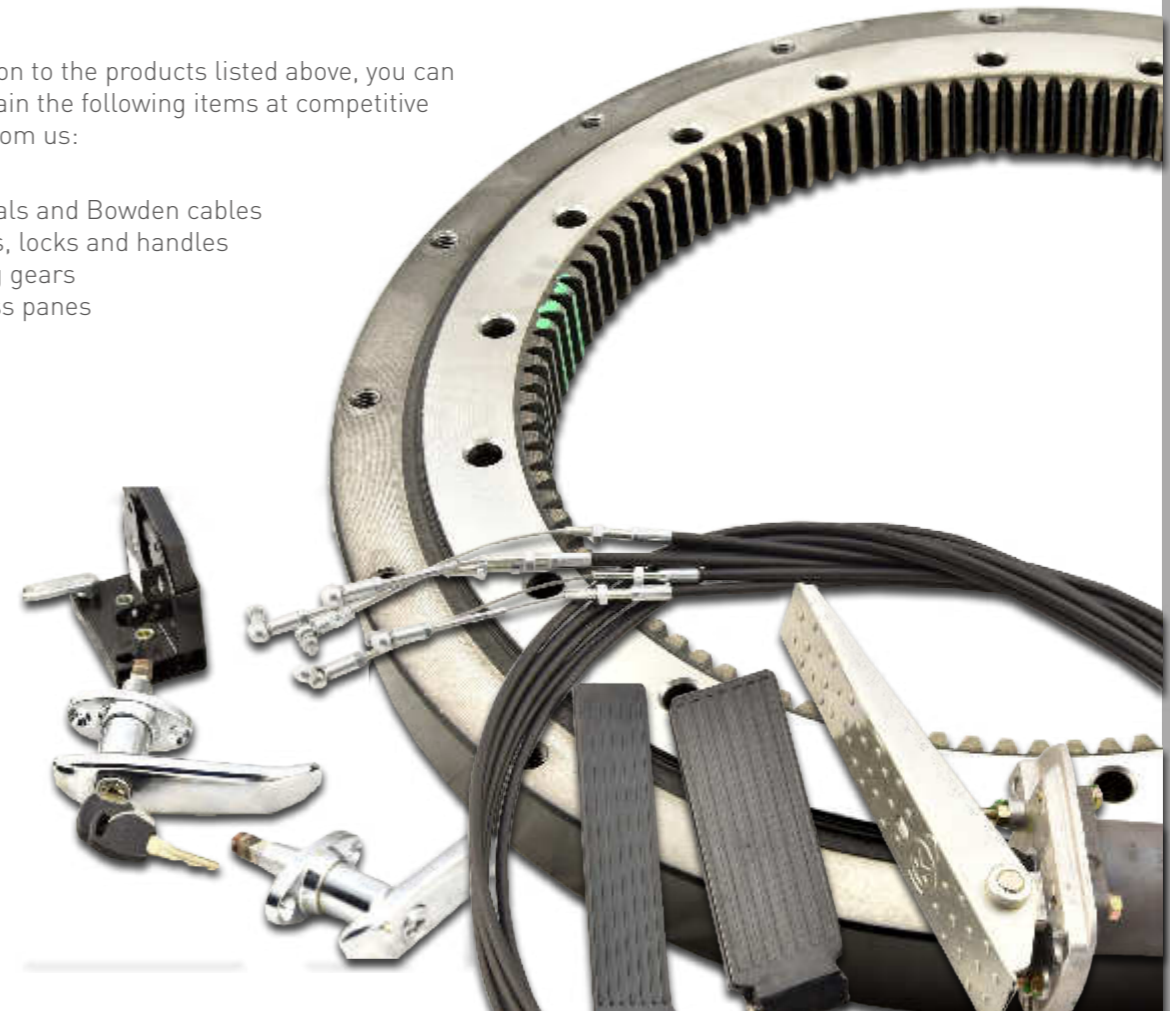

- AHLMANN
- AMMANN
- ATLAS
- BENFORD
- BOBCAT
- CAT MINING
- CATERPILLAR
- CNH
- DOOSAN
- FERMEC
- FUCHS
- FURUKAWA
- HITACHI
- JCB
- KOBELCO
- KOMATSU
- KRAMER
- KUBOTA
- LIEBHERR
- O&K
- SENNEBOGEN
- TAKEUCHI
- TEREX
- VOLVO
- WACKER NEUSON
- WEIDEMANN
- WEYCOR
- WIRTGEN
- YANMAR



HANOMAG

Hannoversche Maschinenbau AG started producing construction machinery in Hanover in 1931. The very popular wheel loaders and dozers were produced in Hanover until the mid-1990s. The solid construction of HANOMAG machinery ensured that they are still being used today in large numbers.

Many owners of these legends machinery swear by their quality. The technology is simple, easy to repair, yet effective. HANOMAG construction machinery can be maintained by skilled technicians, as they did not yet contain any complex software or sensors.

HANOMAG SPARE PARTS FROM KRAEMER

We are still able to provide a wide range of spare parts for your HANOMAG, even today. Our employees have built up a wide range of expertise over decades, as well as a specific stock of spare parts for the machinery.

Since 1974, Kraemer has been a long-standing, strong partner of HANOMAG. When HANOMAG first started having problems with their supply of spare parts in the mid-1980s, we started to collaborate with the original parts manufacturers. This has resulted in a comprehensive network of parts suppliers, who are still supplying us directly today.

We will gladly support you to ensure that you can continue to use your HANOMAG! If you have a spare parts problem, why not contact us.

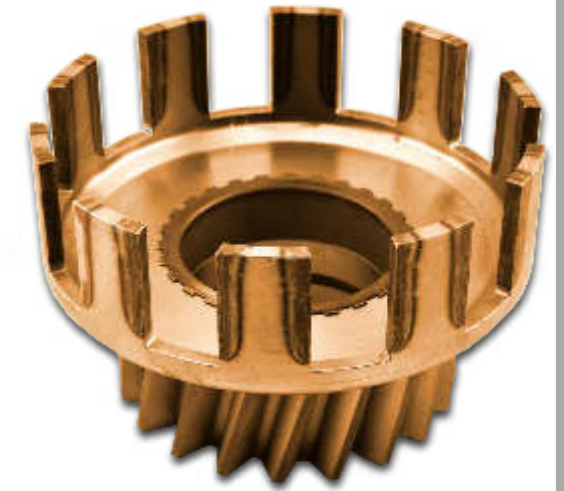

SUITABLE FOR YOUR REQUIREMENTS

- ✓ ORIGINAL EQUIPMENT QUALITY
- ✓ ALTERNATIVE QUALITY
- ✓ MAINTENANCE

IMMEDIATELY AVAILABLE

- ✓ LARGE STOCK ON HAND
- ✓ DAILY DELIVERY

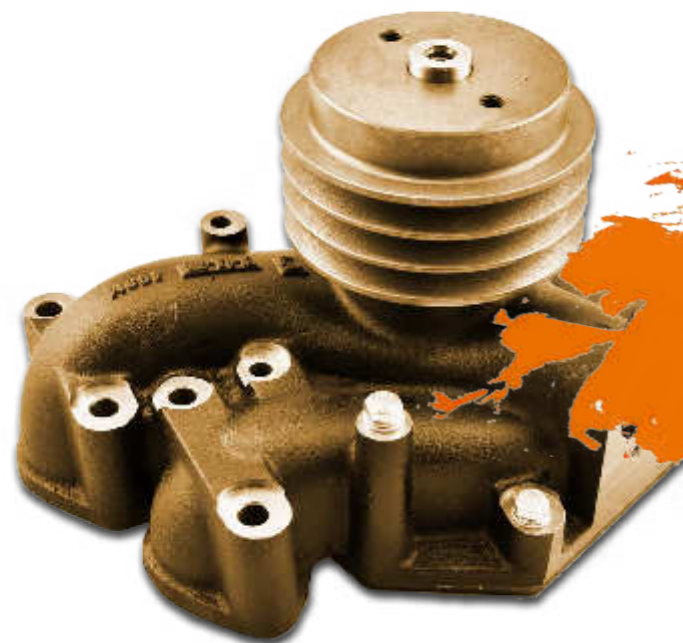

WHEEL LOADERS

22C/D

33C/D

44C/D

55C/D

66C/D

70C/D

35D

20E

50E

60E

70E

10F

15F

20F

AND MORE ...

DOZERS

D600C/D

D700D

D540E

D680E

L600C

L700C/D



EXPRESS DELIVERY!



THE FACTS

- ✓ 3,500 m² warehouse with 16,000 m² warehouse
- ✓ Stock of 22,000 spare parts always in stock
- ✓ Over 9 million items can be identified and ordered via the Kraemer system
- ✓ The latest logistics and warehouse technology
- ✓ Daily delivery of your spare parts
- ✓ Express delivery



QUESTIONS?

WE WILL CONNECT YOU WITH THE RIGHT CONTACT PERSON, WHO WILL HAVE AN ANSWER TO YOUR QUESTIONS AND REQUIREMENTS!

T +49 (0)2522 8388-0
 F +49 (0)2522 8388-111
export@kraemer24.com

EXPORT SALES



DIRECTOR
 VALENTIN RERICH



SENIOR MANAGER
 ZOYA HÖHN



MANAGER
 VLADIMIR BOKK



MANAGER
 ALEXANDER KNELZ

ADDITIONAL SERVICES

- ✓ Telephone consulting in various languages (DE, EN, PL, RU and others)
- ✓ Demand and stock planning in line with your machinery fleet
- ✓ Delivery to your branches, customers, technicians or DHL packing stations
- ✓ Used parts, repair or exchange
- ✓ Compilation of individual service kits
- ✓ Assistance with parts identification
- ✓ Customs handling
- ✓ Neutral delivery

THREE SKILLS UNDER A SINGLE ROOF!

KRAEMER

IT WORKS.

KRAEMER
BAUMASCHINEN

KRAEMER
ERSATZTEILE

KRAEMER
MINING

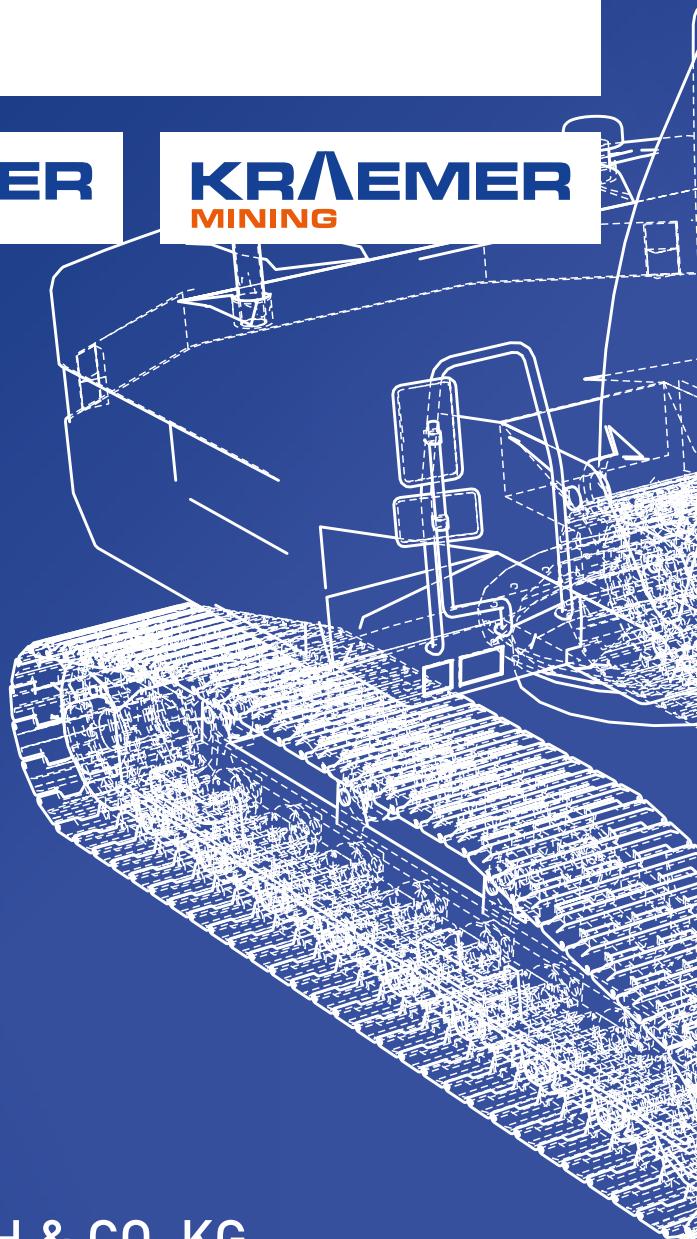

Member of



KRAEMER BAUMASCHINEN GMBH & CO. KG

Headoffice:

Ferdinand-Braun-Str. 3
33378 Rheda-Wiedenbrück
T +49 (0)2522 8388-0
F +49 (0)2522 8388-111

Lippstadt

Bertramstr. 2
59557 Lippstadt

Dortmund

Martener Hellweg 100
44379 Dortmund

Osnabrück

Werner-von-Braun-Str. 15
49134 Wallenhorst

www.kraemer24.com
info@kraemer24.com

